

PROJECT
TYPE
CATALOG #

02-BLEM-INDRV-HBR

INLINE LED EMERGENCY DRIVER FOR ROUND HIGH BAY

ILLUMINATION

- Provides voltage to the Input side of the connected load during emergency mode operation.
- For use with switched or unswitched fixtures.
- Can be used with LED lamp/luminaire loads providing up to 30W, 40W and 60W of constant power in Emergency mode.
- Optional remote available for manual testing.

ELECTRICAL

- Universal 100-347V, 50/60Hz input.
- 145VDC, 6A max. output.
- Charge/Power "ON" LED indicator light and push to test switch for mandated code compliance testing.
- Long-life, maintenance free, rechargeable Lithium battery.
- With multi-protection function: overcharge; over-discharge; output overload; short-circuit and open load protection.
- 90-minute minimum emergency operating time over full temperature range.
- 24 hour maximum battery recharge time.
- SDT standard: Self-Diagnostic feature performs monthly and annual tests to ensure reliable operation and meet electrical and safety codes.
- Integral LED indicator light and test switch included.

HOUSING

- Durable painted diecast aluminum construction.
- Provided with mounting rings on both ends.

MOUNTING

- Suitable for top mount of LED fixtures.
- Connected Luminaire not required to be opened for installation or to make electrical connections.

WARRANTY/LISTING

- UL Listed for factory or field installation.
- Suitable for damp location (0°C - 50°C).
- 5 year warranty on all electronics and housing.
- Meets UL924, NFPA 101 Life Safe Code, NEC, OSHA, Local and State codes.
- Complies with FCC part 15, class B.
- Certified to CEC under Title 20 regulations.
- IP69K Protection.

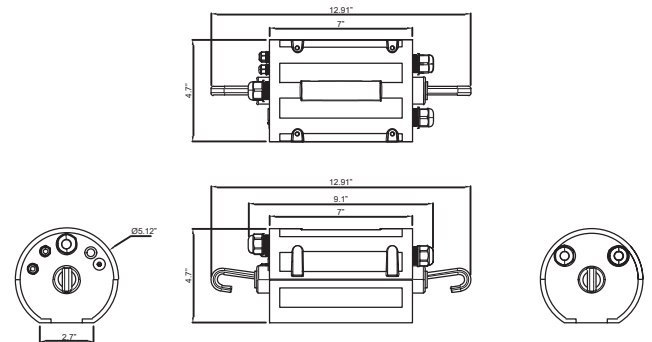

Model	Size (inches) & Weight (lbs)			
	L (in)	W (in)	H (in)	Weight
02-BLEM-INDRV-HBR	12.91	5.1	4.7	4.64



PRODUCT PARAMETERS

MODEL	OUTPUT POWER
02-BLEM-INDRV	HBR30 30 Watts
	HBR40 40 Watts
	HBR60 60 Watts



PROJECT
TYPE
CATALOG #

02-BLEM-INDRV-HBR

INLINE LED EMERGENCY DRIVER FOR ROUND HIGH BAY

ACCESSORIES (order separately)

Remote Controller:

20-EM-01R = Remote control required for programming (sold separately)

ELECTRICAL DATA

Models	02-BLEM-INDRV-HBR30W	02-BLEM-INDRV-HBR40W	02-BLEM-INDRV-HBR60W
Recharge Duration	24Hours	24Hours	24Hours
Emergency Wattage	30W	40W	60W
Battery Capacity	14.4V / 5200mAh	14.4V / 6600mAh	14.4V / 9900mAh
Compatible LED Fixture	9-240W LED lamp with 0-10V dimming or LED lamp less than 30W without 0-10V dimming	9-350W LED lamp with 0-10V dimming or LED lamp less than 40W without 0-10V dimming	9-500W LED lamp with 0-10V dimming or LED lamp less than 60W without 0-10V dimming