

FEATURES

- Newest design with 5 Manual Switches, easy programming.
- 12VDC Input, 0-10V Dimming, with Daylight Harvesting and Photocell Function.
- Elegant and classic round design, with rotators for easy programming.
- Rotator & Remote control.

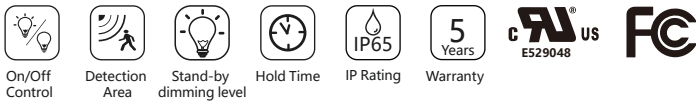

HD09VR-PH5-1

TECHNICAL DATA

PIR Information

Infrared Wavelength	5-14um
Output Signal Peak	≥3500mV
PIR Sensitivity	3200V/W
Installation Height	≤12m/39.37ft
Detection Distance	3-7m/9.84-22.96ft
Detection Angle	<120° Fersnel Lens
Working Temp	-20°C~+60°C

Electrical Specifications

Input Range	12-24VDC
Stand-by Power	<15mA
Warm-up Period	50s
Output control	Should be ON/OFF 0-10V DIM

Match Emergency Drivers

*Work compatibly with EM driver, please make sure it follows below conditions:

1. Switching capacity <1mA
2. LED driver' s OFF voltage at 1mA is 0.25-0.3V
3. Single fixture connected.

Sensor Parameter

Control Device	Remote Control #HD06R(purchase separately) Manual Switches
Detection Area	Remote Control : 25% / 50% / 75% / 100% Rotating switch: 25% / 50% / 75% / 100%
Holdtime	Remote Control: 5s / 30s / 1min / 3min / 5min / 10min / 20min / 30min Rotating switch: 5s/1min/ 5min/10min
Daylight Threshold	Remote Control: 2lux / 10lux / 30lux / 50lux / 80lux / 120lux / 200Lux / 250Lux / 300lux / 350Lux / 400Lux / Disable Rotating switch: 50Lux / 200Lux / 400Lux / Disable
Standby Period	Remote Control: 0s / 10s / 30s / 1min / 5min / 10min / 30min / 60min / +∞ Rotating switch: 0s / 10min / 30min / +∞
Standby Dimming Level	Remote Control: 10% / 20% / 30% / 50% Rotating switch: 10% / 20% / 30% / 50%
Automatically Dimming (Daylight Harvesting)	1. Stay in SENSOR MODE 2. STANDBY PERIOD as 0S 3. DAYLIGHT as any of 50Lux / 80Lux / 120Lux / 200Lux / 250Lux / 300Lux / 350Lux / 400Lux 4. Press DAYLIGHT HARVESTING button to ON
Automatically ON/OFF (Photocell)	1. STANDBY DIM LEVEL as any of 10% 20% 30% 2. STANDBY PERIOD as infinite 3. DAYLIGHT as any of 30Lux / 50Lux / 80Lux / 120Lux / 200Lux / 250Lux / 300Lux / 350Lux / 400Lux

DIMENSIONS

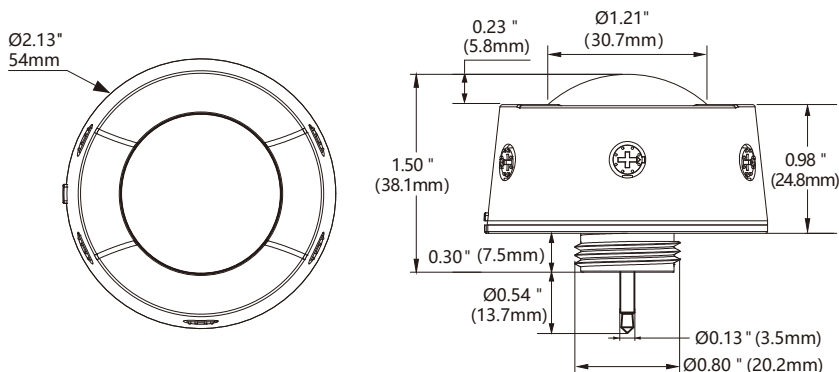

PROGRAMMING

- ① Detection Area
25% / 50% / 75% / 100%
- ② Holdtime
5s/1min/ 5min/10min
- ③ Daylight Threshold
50Lux / 200Lux / 400Lux / Disable
- ④ Standby Period
0s / 10min / 30min / +∞
- ⑤ Standby Dimming Level
10% / 20% / 30% / 50%



FACTORY SETTING

1. Detection Area - 100%
2. Holdtime - 5S
3. Daylight Threshold - disable
4. Standby Period - 0S
5. Standby Dimming Level - 10%

DETECTION COVERAGE

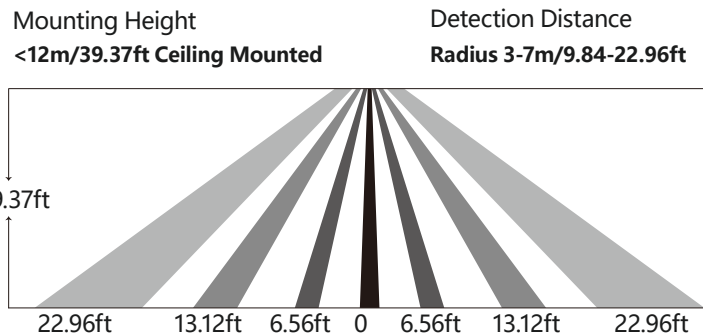
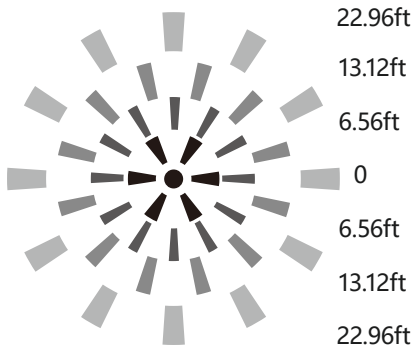

PERFORMANCE

1. Daylight Harvesting

Please follow below setting steps to perform this function:

1. Stay in SENSOR MODE
2. STANDBY PERIOD as 0S
3. DAYLIGHT as any of 50Lux / 80Lux / 120Lux / 200Lux / 250Lux / 300Lux / 350Lux / 400Lux
4. Press DAYLIGHT HARVESTING button to ON

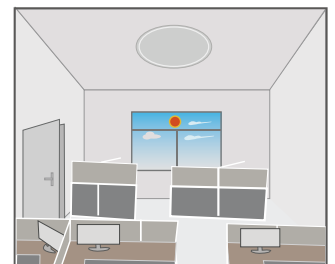
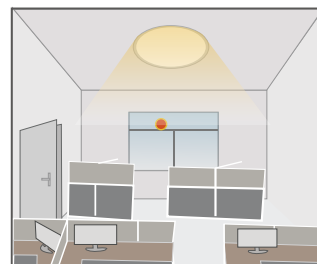
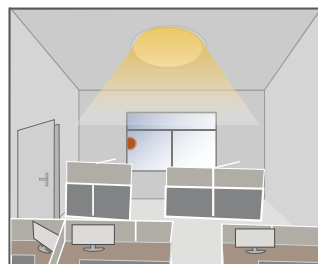
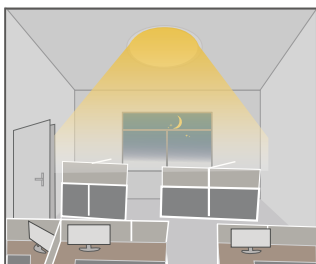
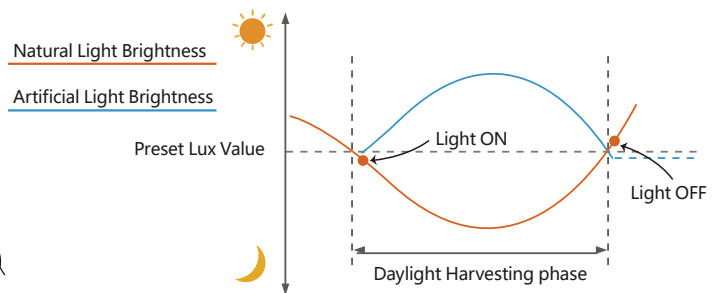

When ambient brightness is lower than preset lux level, sensor will turn on light automatically and keep dimming according to the change of the ambient brightness; when outside is getting darker, the inside will be brighter, and brighter darker.

Light OFF when ambient brightness becomes higher than the preset lux level.

2. Dusk/Dawn function

HD09VR is able to differentiate artificial light brightness from natural light after installed inside the fixture, and automatically turn off light when ambient brightness exceeds preset lux level.

Please follow below setting steps to perform this function:

1. STANDBY DIM LEVEL as any of 10% 20% 30%
2. STANDBY PERIOD as infinite
3. DAYLIGHT as any of 30Lux / 50Lux / 80Lux / 120Lux / 200Lux / 250Lux / 300Lux / 350Lux / 400Lux

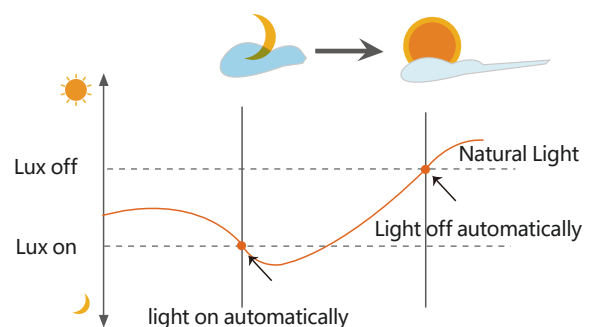

3. With Dusk/Dawn function

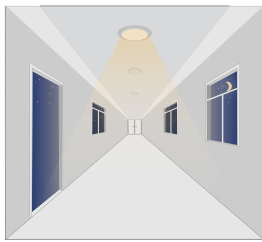

With insufficient ambient brightness, sensor turns on light and keeps it at standby dimming level even if there is no motion or presence.

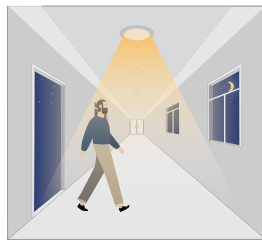

When sensor detects motion or presence it will bring the light level up to 100%.

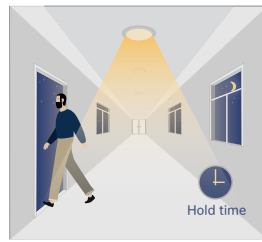

After motion is no longer detected, fixture remains at 100% for hold time.

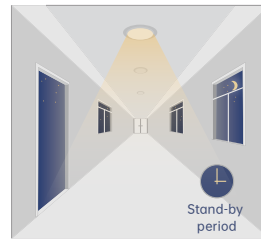

After pre-set hold time period it will dim light to standby dimming level again and always keep it.

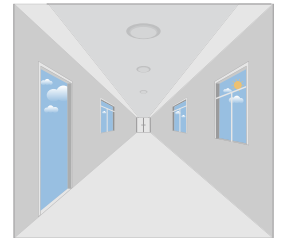

With sufficient ambient brightness, sensor will turn OFF light automatically.

4. Without daylight disabled

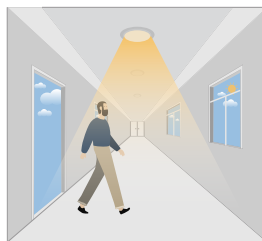

Sensor turns ON light when motion is detected.

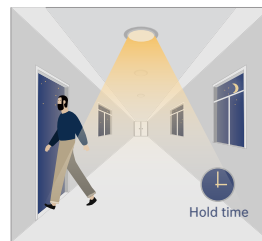

Sensor keeps for a hold time period after motion leaves

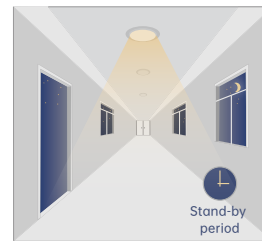

Sensor dims light to standby dimming level after hold time if there is still no motion

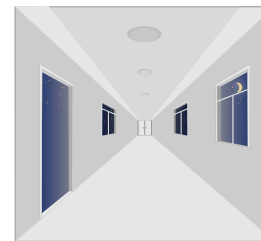

Sensor turns OFF light after standby period

5. With Daylight Threshold

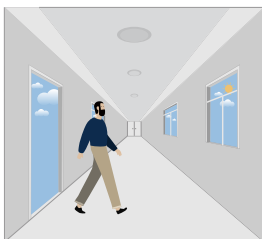

With sufficient daylight, the sensor keeps light OFF even motion gets detected

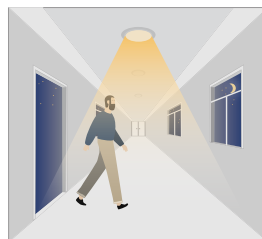

With insufficient daylight, the sensor turns light ON when motion gets detected

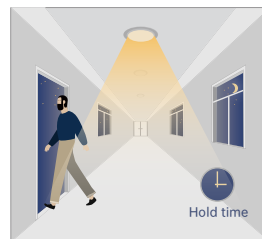

After there's no motion detected, the sensor keeps light ON 100% for holdtime.

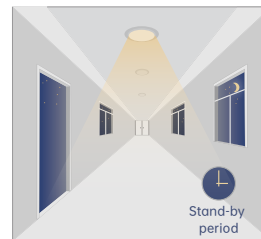

After holdtime, sensor dims light to standby dimming level for standby period. if the standby period has been set as 0s, sensor turns light OFF automatically after holdtime.

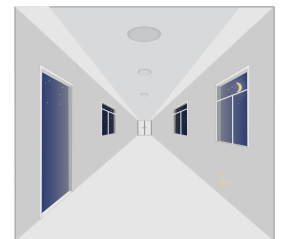

The sensor turns OFF light automatically after the standby period when there's no motion detected.



Attention

1. The sensor should be installed by qualified electrician and ensure power is OFF before installation.
 2. Please read the instruction carefully before using the product and keep it well for other users to read any time.
 3. We reserve the right to modify any incorrect text, image and technical parameters.
 4. Any unauthorized modification is forbidden. Otherwise all guarantees will be immediately invalid.
 5. Product could be optimized without prior notice.
- When ambient temperature approaches the human body classic temperature range(36°C~37°C/96.8~98.6°F), PIR sensor's detecting performance will significantly weaken or non-responsive.
 - When ambient temperature stays higher then 40°C/104°F, PIR sensor's detecting performance will significantly weaken.

APPLICATION NOTES

1. Suitable for indoor application, half/completely outdoor environment conditions might trigger the sensor.
2. Suitable for ceiling mount installation, adjust sensitivity properly if it's installed on side-wall because it gets more sensitive.
3. PIR sensor can't be placed inside any material, fresnel lens must completely exposed in air.
4. Fresnel lens of the PIR sensor must be lower than light fixture.
5. Not suitable environment if there's sudden changed temperature of airflow for PIR sensor.
6. Not suitable environment if there's shelves blocking between the sensor and presence area.
7. Detection area options may NOT working obviously because it works depends on fresnel lens, it's physically defined.
8. Detection distance performance works better when moving parallelly than moving towards to the sensor.
9. Daylight testing delivered in bright day without shadow or specially designed lampshade or lens.
10. Dimming performance differs when connected to different drivers; If the driver can't completely turn OFF, sensor can't either.
11. Input power voltage must be stable with float less than 10%.
12. The first time powered ON sensor, light will be ON 100% for about 45S then dims to standby level or OFF.
13. Distance detection is delivered by testing person about 165cm in open area as reference, the result differs by size and speed of moving objects, mounting height and real-life situation.

NOTE:

This equipment has been tested and found to comply with the limits for a Class A digital device, pursuant to part 15 of the FCC Rules. These limits are designed to provide reasonable protection against harmful interference in a commercial installation. This equipment generates, uses, and can radiate radio frequency energy and, if not installed and used in accordance with the instructions, may cause harmful interference to radio communications. However, there is no guarantee that interference will not occur in a particular installation. If this equipment does cause harmful interference to radio or television reception, which can be determined by turning the equipment off and on, the user is encouraged to try to correct the interference by one or more of the following measures:

- Reorient or relocate the receiving antenna.
- Increase the separation between the equipment and receiver.
- Connect the equipment into an outlet on a circuit different from that to which the receiver is connected.
- Consult the dealer or an experienced radio/TV technician for help.