

PROJECT
TYPE
CATALOG #

## 02-HPEM

### LED HIGH PERFORMANCE EMERGENCY THERMOPLASTIC UNIT

#### FEATURES

- Ultra-bright, energy efficient, long-life White LED adjustable lamp heads provide up to 100-ft center-to-center spacing with a 3-ft path of egress at 7-1/2-ft mounting height
- High performance chrome-plated metallized reflector and plastic lens
- 12.0 watt (12 LEDs x 1.0 watt) per head
- Universal 120-277 voltage
- Unique bi-color LED indicator light alerts occupant on battery condition (Green-normal, Red-check battery)
- Charge rate/power "ON" LED indicator light and push-to-test switch for mandated code compliance testing
- 9.6V long-life, maintenance-free, rechargeable lithium iron phosphate battery
- Remote capacity of 3.0 watts standard
- Fully automatic solid-state, two rate charger initiates battery charging to recharge a discharged battery in 24 hours
- Universal knockout pattern on back plate for surface mount
- Knockouts provided for conduit feed applications
- Suitable for wall or ceiling mount
- Injection-molded, engineering grade, 5VA flame retardant, high-impact resistant, thermoplastic in white or black finish



#### DIMENSIONS

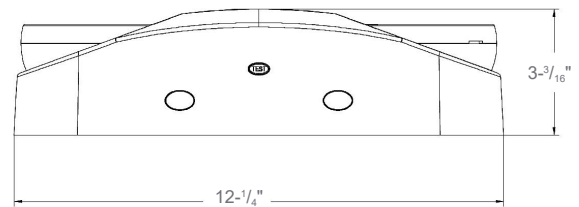
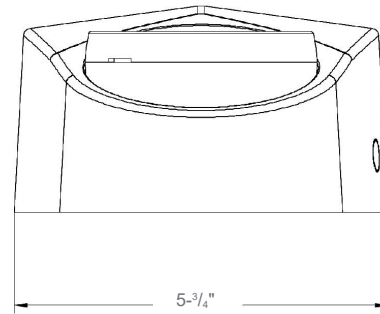

#### WARRANTY & LISTINGS

- Five-year warranty on all electronics and housing. Battery prorated for five years
- Meets UL924, NFPA 101, Life Safety Code, NEC, OSHA, Local and State Codes
- UL Listed for damp locations (0°C – 50°C)

#### PRODUCT PARAMETER

MODEL	HOUSING COLOR	
02-HPEM	W	WHITE
	B	BLACK