

PROJECT
TYPE
CATALOG #

06-BL4TCLD 4" LED ARCHITECTURAL CAN & FRAME-IN KIT

APPLICATIONS

The Energy Star 06-BL4TCLDseries is a 4" commercial grade architectural can & frame-in kit. Built for commercial use with architectural frames and a deep cone reflector for precision light. This high-efficiency luminaire provides long life - offered in two wattages and color temperatures.

FEATURES

- Architectural frames
- C channel and flat hanger bars for tie down to ceiling grids
- 21 Watt available in 3000K
- 28 Watt available in 4000K
- Junction box is mounted on the frame for easy wiring,driver access for installation, and replacement
- Diecast aluminum heatsink dissipates heat from the LED board
- Self-flanged aluminum reflector with a frosted lens to shield direct view of LEDs
- Color rendering index ≥ 80
- Long life LEDs - up to 50,000 hours
- Universal 120-277 AC voltage (50/60Hz)
- 0-10V dimming
- Operation Temp. $-30^{\circ}\text{C}\sim 40^{\circ}\text{C}$ ($-22^{\circ}\text{F}\sim 104^{\circ}\text{F}$)

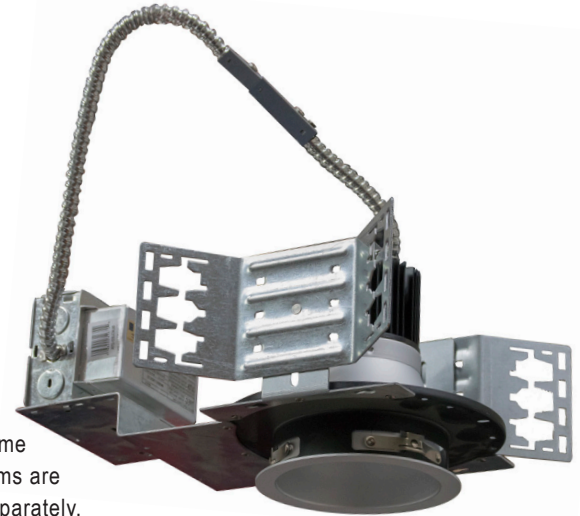

Trim & Frame shown. Items are ordered separately.



WARRANTY & LISTINGS

- cULus Listed
- ENERGY STAR® rated
- RoHS compliant
- 5-Year Warranty of all electronics and housing

DIMENSIONS

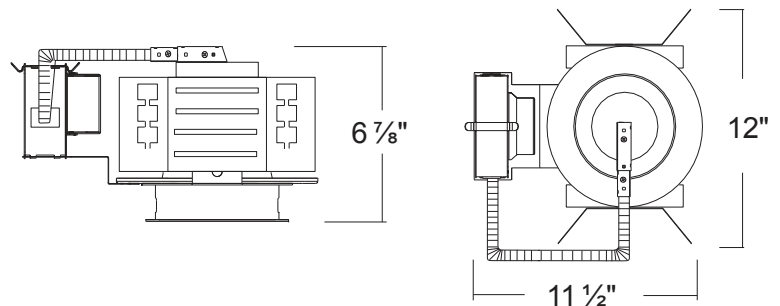

ORDERING INFORMATION

MODEL	LUMINAIRE WATTS	LUMINAIRE LUMENS	LUMENS PER WATT	COLOR TEMPERATURE	FRAME REQUIRED
06-BL4TCLD-21HZ-3K	21	1590	76	3000k	06-BL4CLED-21A
06-BL4TCLD-28HZ-4K	28	1940	69	4000k	06-BL4CLED-28A