

PROJECT
TYPE
CATALOG #

WET LOCATION LED EMERGENCY UNIT

02-EWL-LED



ELECTRICAL

- Dual 120/277 voltage
- Can operate up to "2" additional LED remote lamp heads. (3.6V DC output; 3W Max)
- Charge rate/power "ON" LED indicator light and push-to-test switch for mandated code compliance testing
- Internal solid-state transfer switch automatically connects the internal battery to LED lamp heads for minimum 90-minute emergency illumination
- Fully automatic solid-state, two-rate charger initiates battery charging to recharge a discharged battery in 24 hours
- Cold weather feature available with standard unit for freezer applications
- Long life, maintenance-free, rechargeable NiCd battery

HOUSING

- Corrosion-resistant 5VA flame retardant UV stabilized polycarbonate in gray or black finish
- Sealed and gasketed housing with hinged cover
- Sealed test switch
- Integral breather vent

MOUNTING

- External mounting brackets for simplified wall mounting

DIMENSIONS

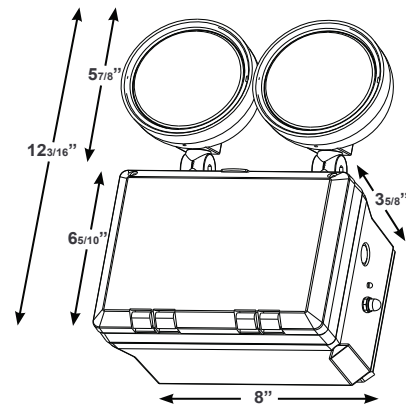

WARRANTY/LISTING

- Five year warranty on all electronics and housing.
- Battery pro-rated for five years
- UL Listed for wet locations
- Meets UL924, NFPA 101 Life Safety Code, NEC, OSHA, Local and State Codes

ILLUMINATION

- Long lasting efficient Ultra-bright white LED lamp heads.
- Sealed and gasketed weather proof lamp heads with high performance chrome plated metallized reflector and tempered glass lenses for optimal light distribution

ORDERING INFORMATION

MODEL	HOUSING COLOR
02-EWL-LED	Blank Gray B Black

**Special Voltage Option Available